

BUILD AN ELF FRIEND

USE WITH GOOGLE SLIDES™

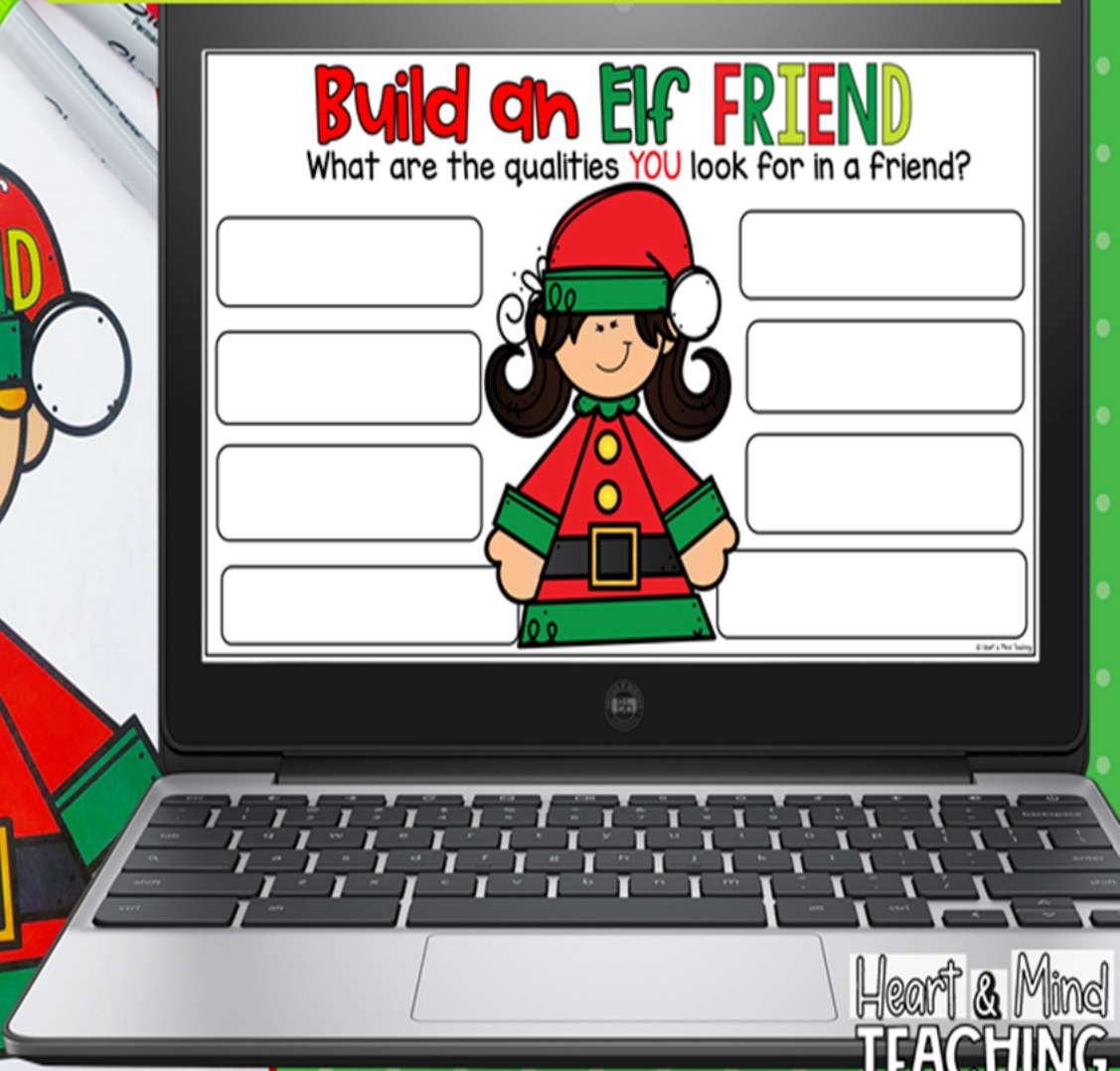

Build an Elf FRIEND

Session Objective:

- *Students will be able to identify traits that they value in a friend.
- *Students will participate and work together.
- *Students will self-reflect on their own traits.

Materials:

- *Build a Friend Activity
- *Pencils, Crayons, Scissors, Glue/Tape

Guiding Questions:

- *What are some traits that are valued in a friend?
- *What traits are not valued in a friend?

Session Details (about 30 minutes)

*Students will each get a copy of one of the Build an Elf Friend page. Explain to them using the sample provided, how the page will look when it is complete. Start at the top of the picture, ask "What would you want your friend to use their brain to do?" Allow students to participate and give responses. Have the students write down the responses they liked and would want their friend to have. Next move to the eyes, ask "What is something that a good friend does with their eyes." Again have the students provide responses and encourage them to write down on their "friend" the ones they like. Move to the following body parts: mouth, ears, hands, heart, feet, and ask for other general qualities they value in a friend. Once there are a good amount of friendship qualities listed, let the students color their "friend". While they are coloring, engage a discussion with questions such as "Why was it important for you to have a friend who you can trust?", "Which is the most important quality for you out of all of the ones you chose?". Point out similarities/differences that the group members chose. Ask "Are the traits you put down on your "friend" all traits that you have? Are there any traits that you are working on and would like to get better at?"

*Show students the "My Elf Friend" and explain that they are going to put qualities they are looking for in a friend on the gifts, there are pre-made ones or they can make their own. Glue the gifts going up, next to the elf, so it stays together (or you can use the version that already has the gifts there). Explain that each Elf friend will be unique because we are all looking for different traits within a friend.

ASCA Standards Alignment:

- *Mindset: Belief in development of whole self, including a healthy balance of mental, social/emotional and physical well-being. (M 1)
- *Behavior: Social Skills: Use effective oral and written communication skills and listening skills. (B-SS 1)
- *Behavior: Social Skills: Create positive and supportive relationships with other students. (B-SS 2)

SEL Competencies:

- *Self-awareness: recognizing strengths, accurate self-perception.
- *Relationship skills: relationship building, communication, social engagement.
- *Social-awareness: Respect for others, appreciating diversity.

Build an Elf FRIEND

Thinks before they speak.

Makes good choices.

Looks at me when we are talking.

Smiles and makes me laugh.

Listens to me when I talk.

Uses kind Words.

Has a caring heart.

Uses hands to help not hurt.

Forgives me when I make mistakes.

Shares with me

Likes similar things that I do.

Trust to stand by my side.

Build an Elf FRIEND

Thinks before they speak.

Makes good choices.

Looks at me when we are talking.

Smiles and makes me laugh.

Listens to me when I talk.

Uses kind Words.

Has a caring heart.

Uses hands to help not hurt.

Forgives me when I make mistakes.

Shares with me

Likes similar things that I do.

Trust to stand by my side.



Build an Elf FRIEND

Thinks before they speak.

Makes good choices.

Smiles and makes me laugh.

Looks at me when we are talking.

Uses kind words.

Listens to me when I talk.

Uses hands to help not hurt.

Has a caring heart.

Forgives me when I make mistakes.

Shares with me.

Trust to stand by my side.

Likes similar things that I do.



Build an Elf FRIEND

Thinks before they speak

Makes good choices.

Looks at me when we are talking.

Smiles and makes me laugh.

Listens to me when I talk.

Uses kind Words.

Has a caring heart.

Uses hands to help not hurt.

Forgives me when I make mistakes.

Shares with me

Likes similar things that I do.

Trust to stand by my side.

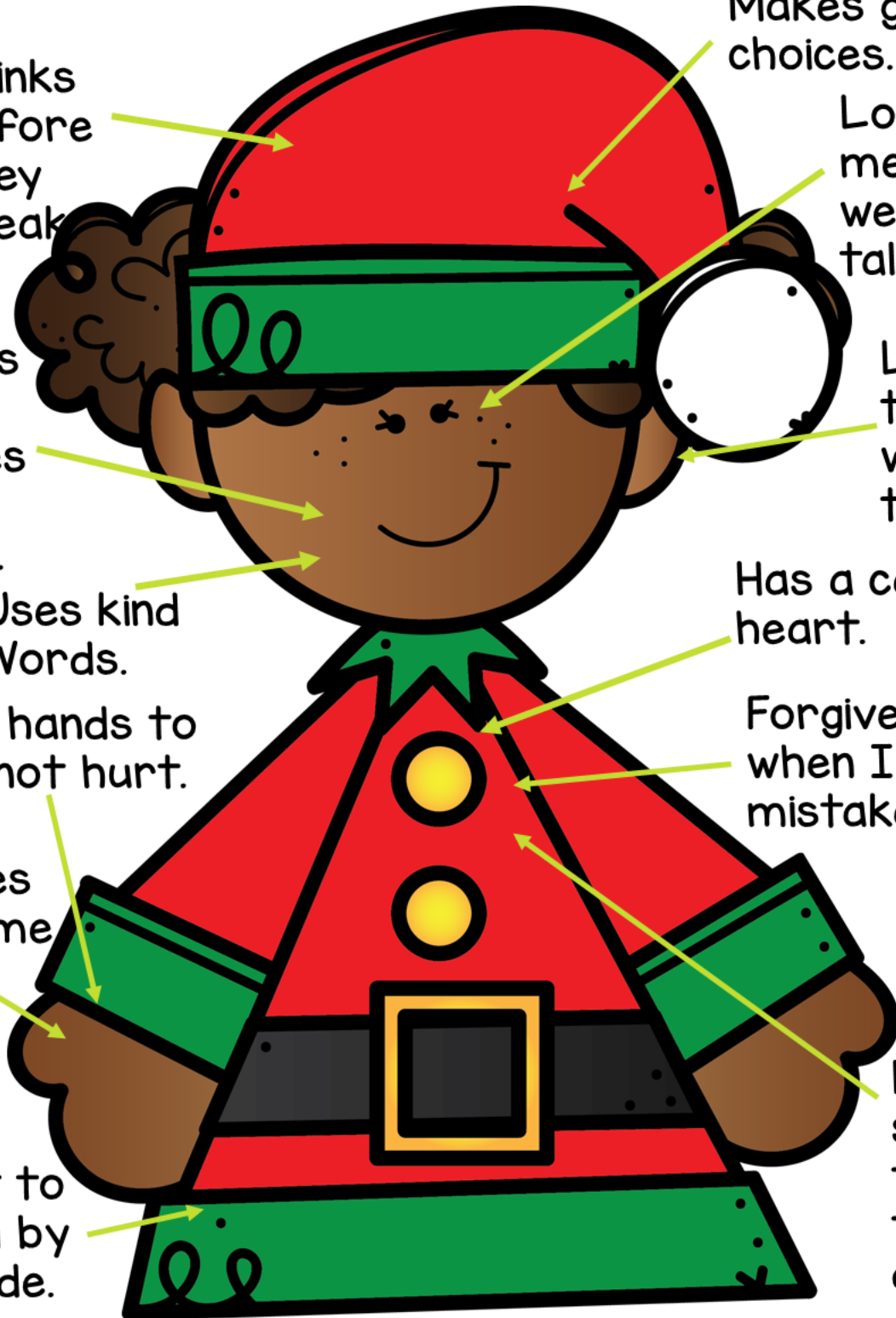

Build an Elf FRIEND



Build an Elf FRIEND



Build an Elf FRIEND



Build an Elf FRIEND



















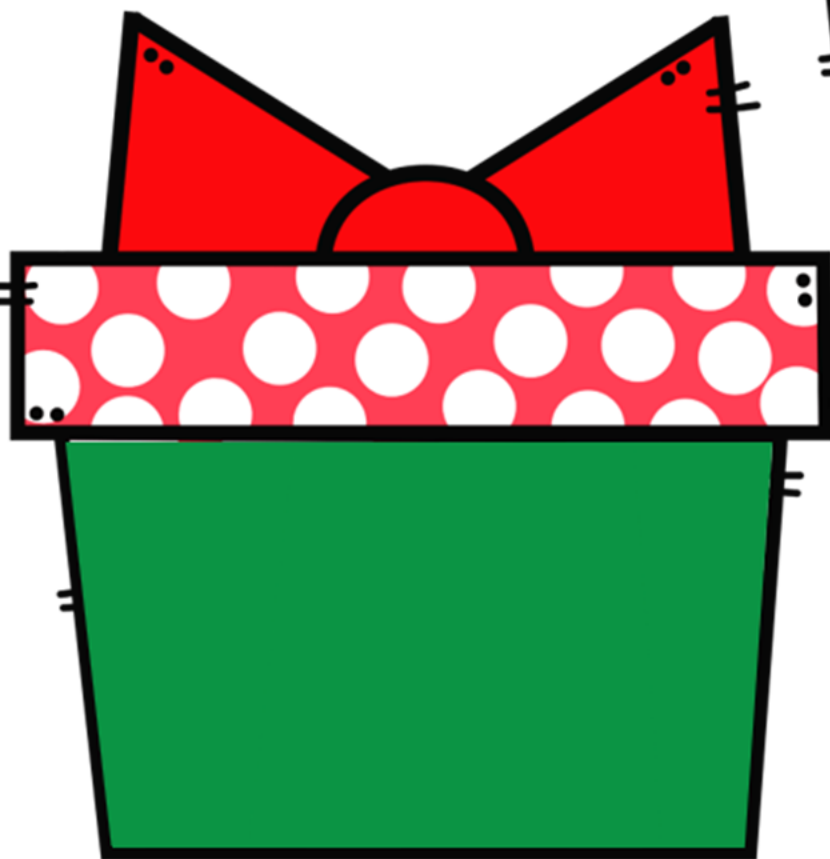
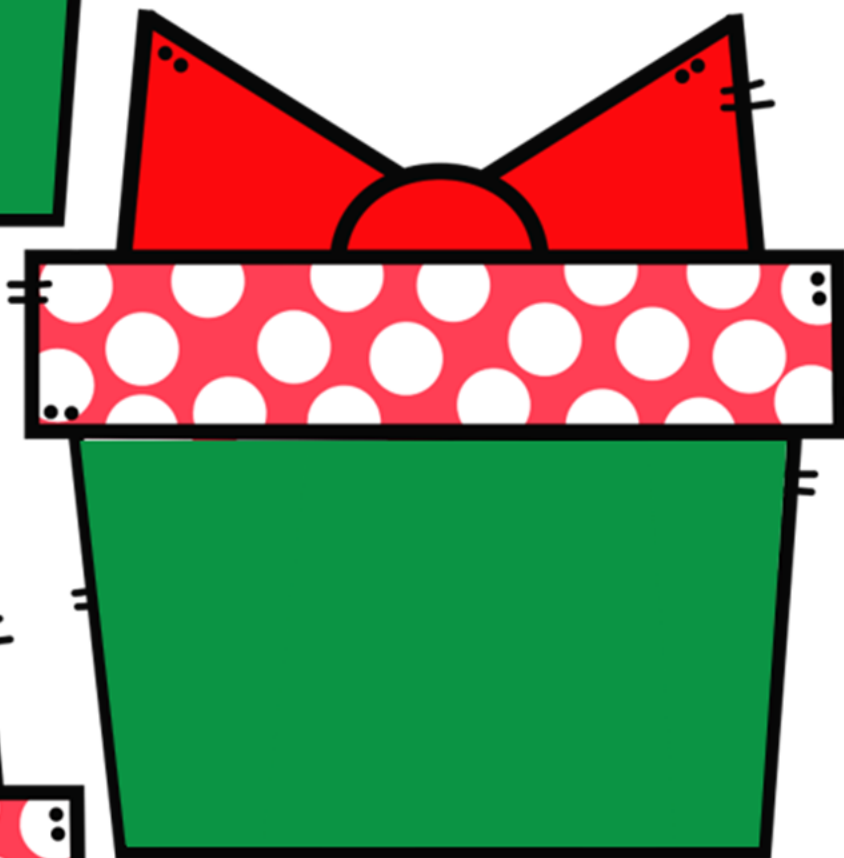











Why is it important for you to know what traits you value in a friend?



A large empty rectangular box for writing an answer to the question above.



Which quality is the most important one to you?

A large empty rectangular box for writing an answer to the question above.



Are the traits you put down on your "friend", traits that you have?



Blank rectangular box for writing.



Are there any traits that you are working on and would like to get better at as a friend?

Blank rectangular box for writing.

Build an Elf FRIEND

Session Objective:

- *Students will be able to identify traits that they value in a friend.
- *Students will participate and work together.
- *Students will self-reflect on their own traits.

Materials:

- *Build a Friend Activity
- *Pencils, Crayons, Scissors, Glue/Tape

Guiding Questions:

- *What are some traits that are valued in a friend?
- *What traits are not valued in a friend?

Session Details (about 30 minutes)

*Students will each get a copy of one of the Build an Elf Friend page. Explain to them using the sample provided, how the page will look when it is complete. Start at the top of the picture, ask "What would you want your friend to use their brain to do?" Allow students to participate and give responses. Have the students write down the responses they liked and would want their friend to have. Next move to the eyes, ask "What is something that a good friend does with their eyes." Again have the students provide responses and encourage them to write down on their "friend" the ones they like. Move to the following body parts: mouth, ears, hands, heart, feet, and ask for other general qualities they value in a friend. Once there are a good amount of friendship qualities listed, let the students color their "friend". While they are coloring, engage a discussion with questions such as "Why was it important for you to have a friend who you can trust?", "Which is the most important quality for you out of all of the ones you chose?". Point out similarities/differences that the group members chose. Ask "Are the traits you put down on your "friend" all traits that you have? Are there any traits that you are working on and would like to get better at?"

*Show students the "My Elf Friend" and explain that they are going to put qualities they are looking for in a friend on the gifts, there are pre-made ones or they can make their own. Glue the gifts going up, next to the elf, so it stays together (or you can use the version that already has the gifts there). Explain that each Elf friend will be unique because we are all looking for different traits within a friend.

ASCA Standards Alignment:

- *Mindset: Belief in development of whole self, including a healthy balance of mental, social/emotional and physical well-being. (M 1)
- *Behavior: Social Skills: Use effective oral and written communication skills and listening skills. (B-SS 1)
- *Behavior: Social Skills: Create positive and supportive relationships with other students. (B-SS 2)

SEL Competencies:

- *Self-awareness: recognizing strengths, accurate self-perception.
- *Relationship skills: relationship building, communication, social engagement.
- *Social-awareness: Respect for others, appreciating diversity.

Build an Elf FRIEND

Thinks before they speak.

Makes good choices.

Looks at me when we are talking.

Smiles and makes me laugh.

Listens to me when I talk.

Uses kind Words.

Has a caring heart.

Uses hands to help not hurt.

Forgives me when I make mistakes.

Shares with me.

Likes similar things that I do.

Trust to stand by my side.

Build an Elf FRIEND

Thinks before they speak.

Makes good choices.

Smiles and makes me laugh.

Looks at me when we are talking.

Uses kind words.

Listens to me when I talk.

Uses hands to help not hurt.

Has a caring heart.

Forgives me when I make mistakes.

Shares with me.

Trust to stand by my side.

Likes similar things that I do.

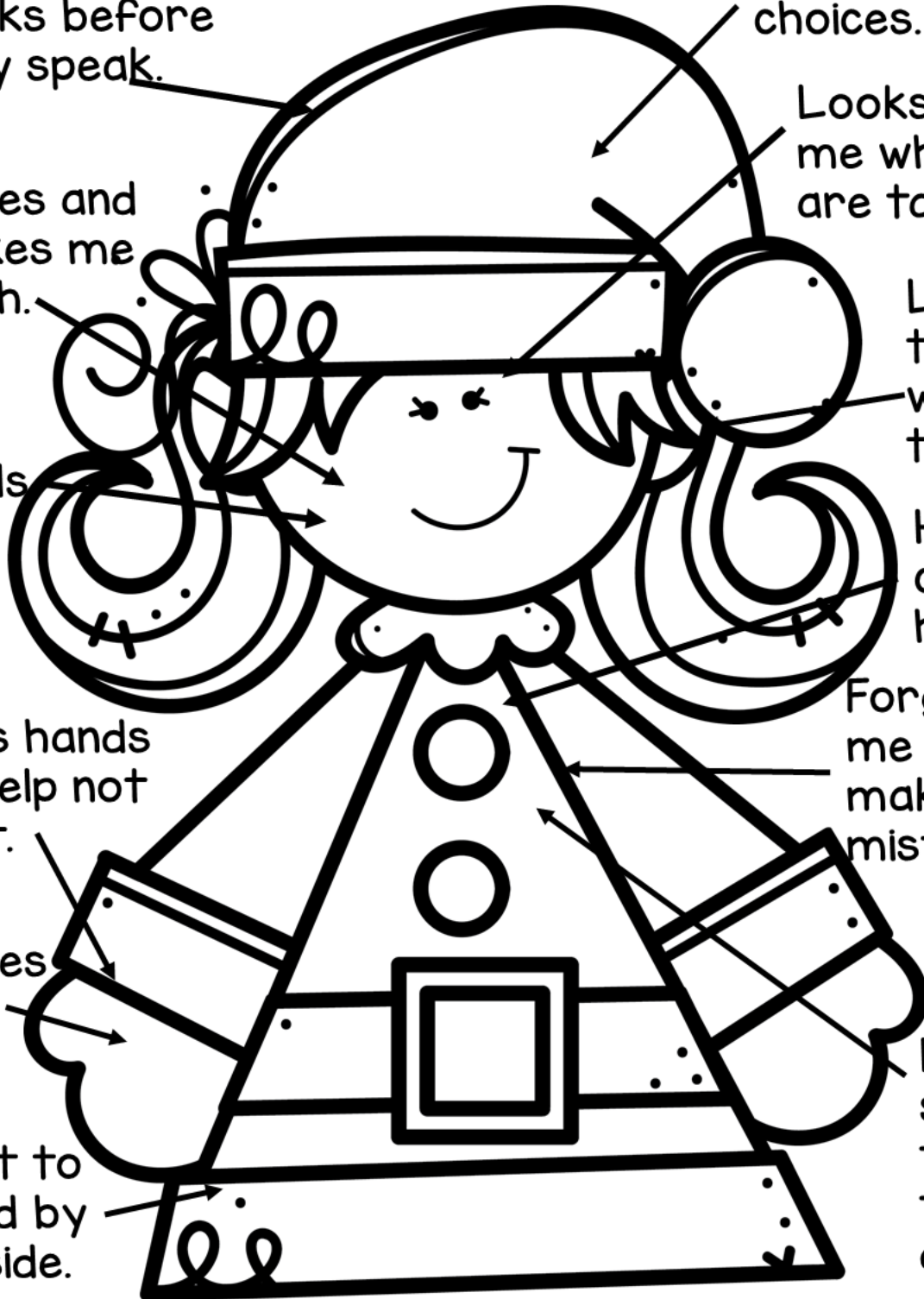

Build an Elf FRIEND

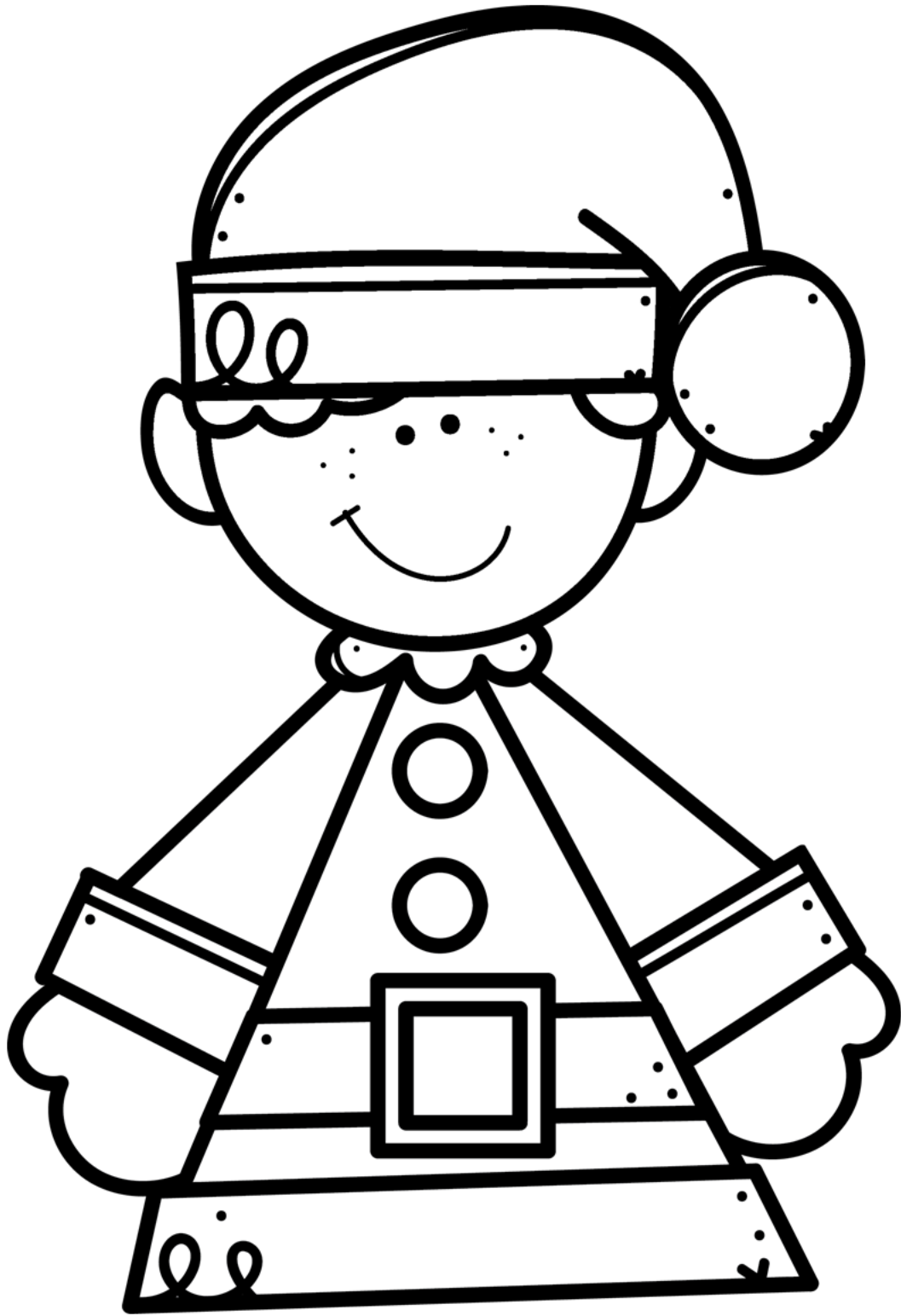

Build an Elf FRIEND

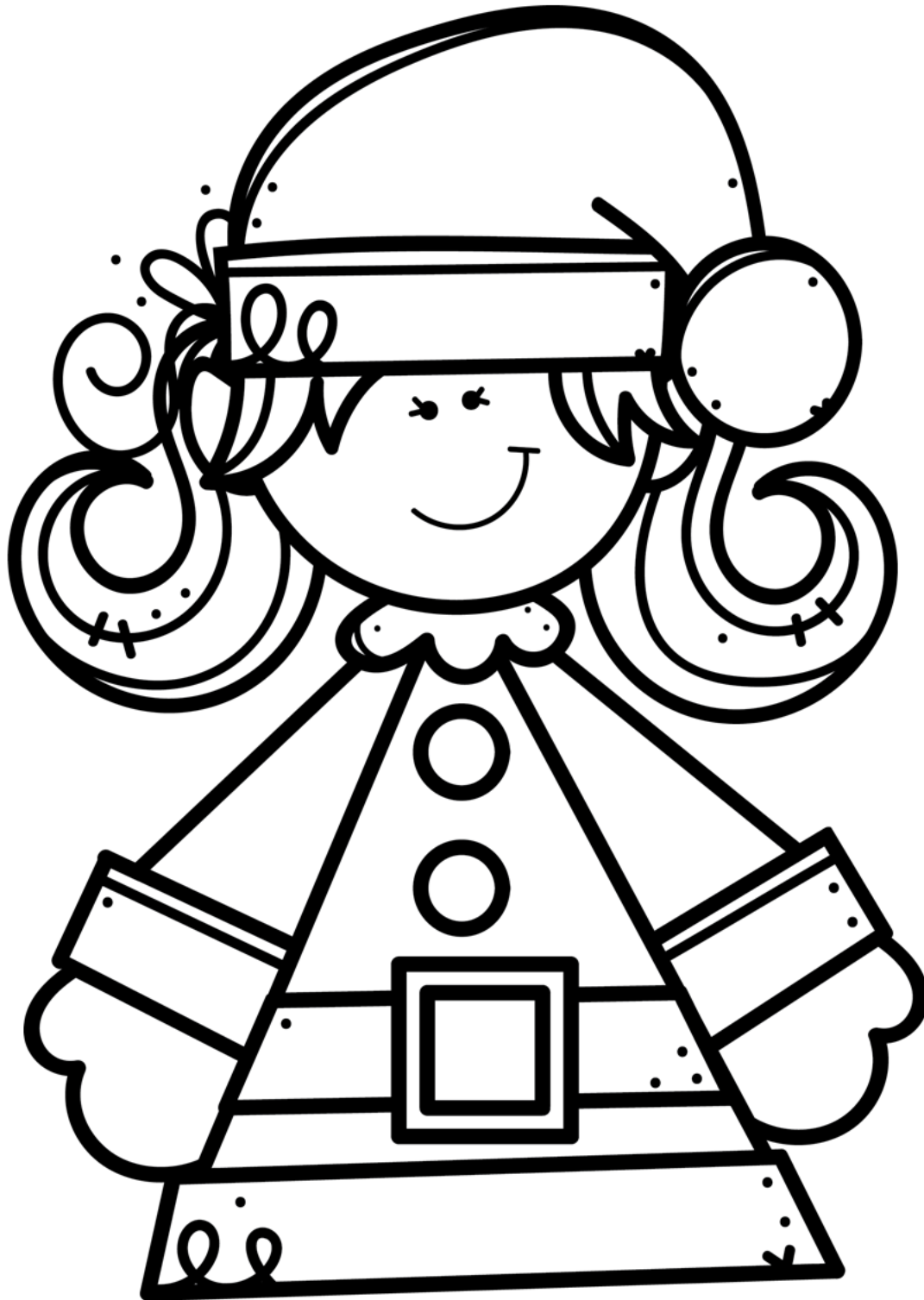

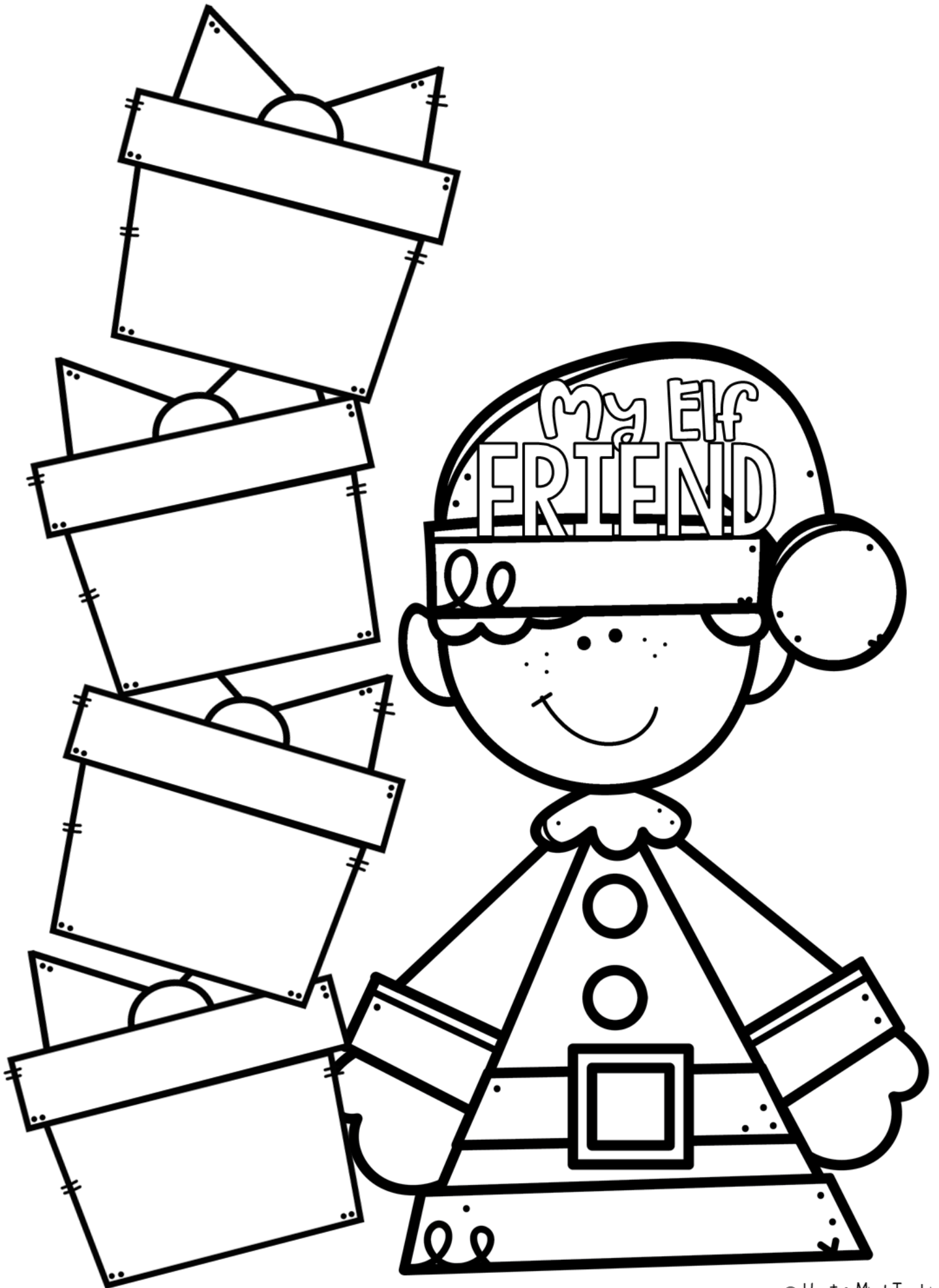

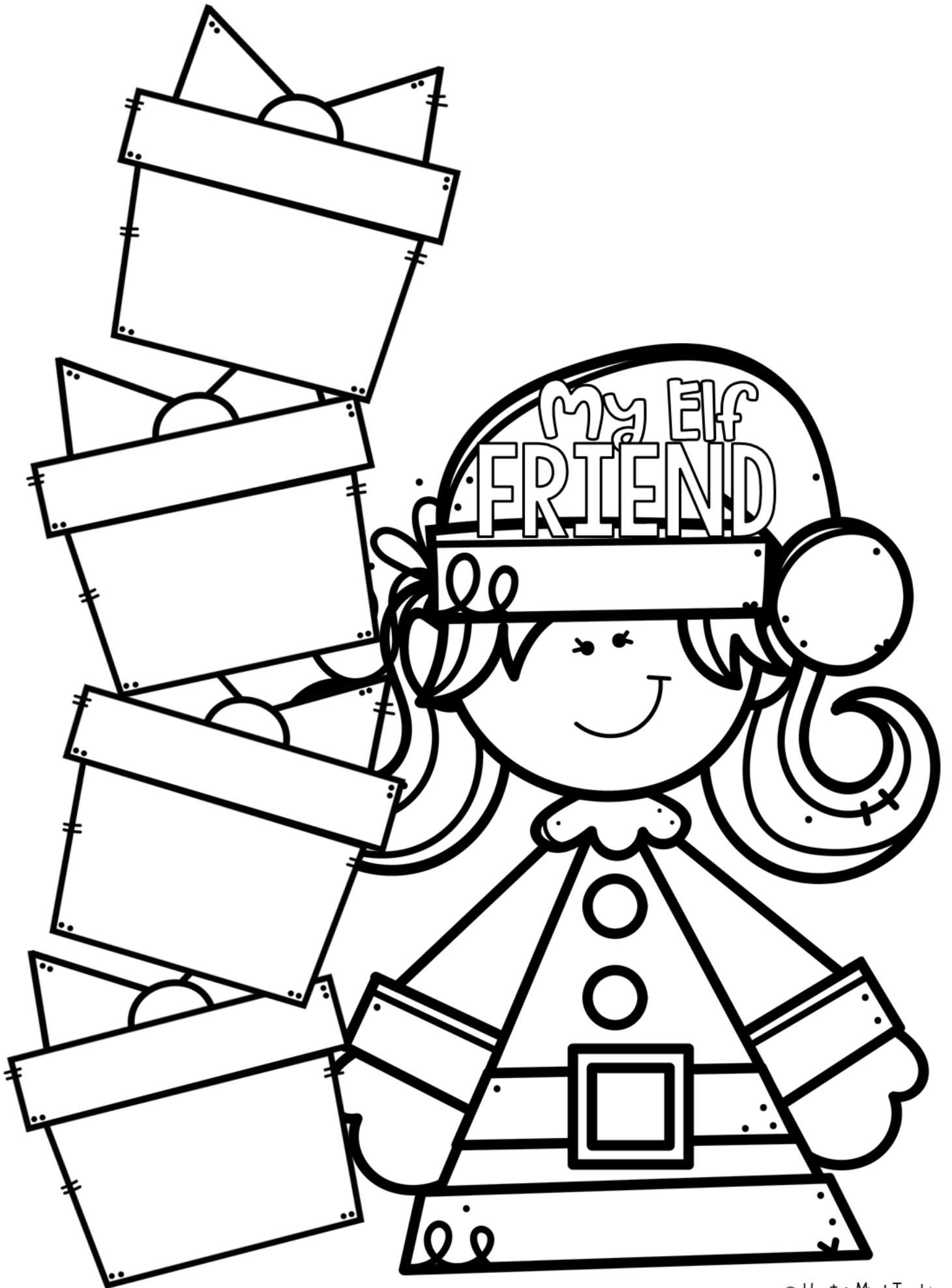

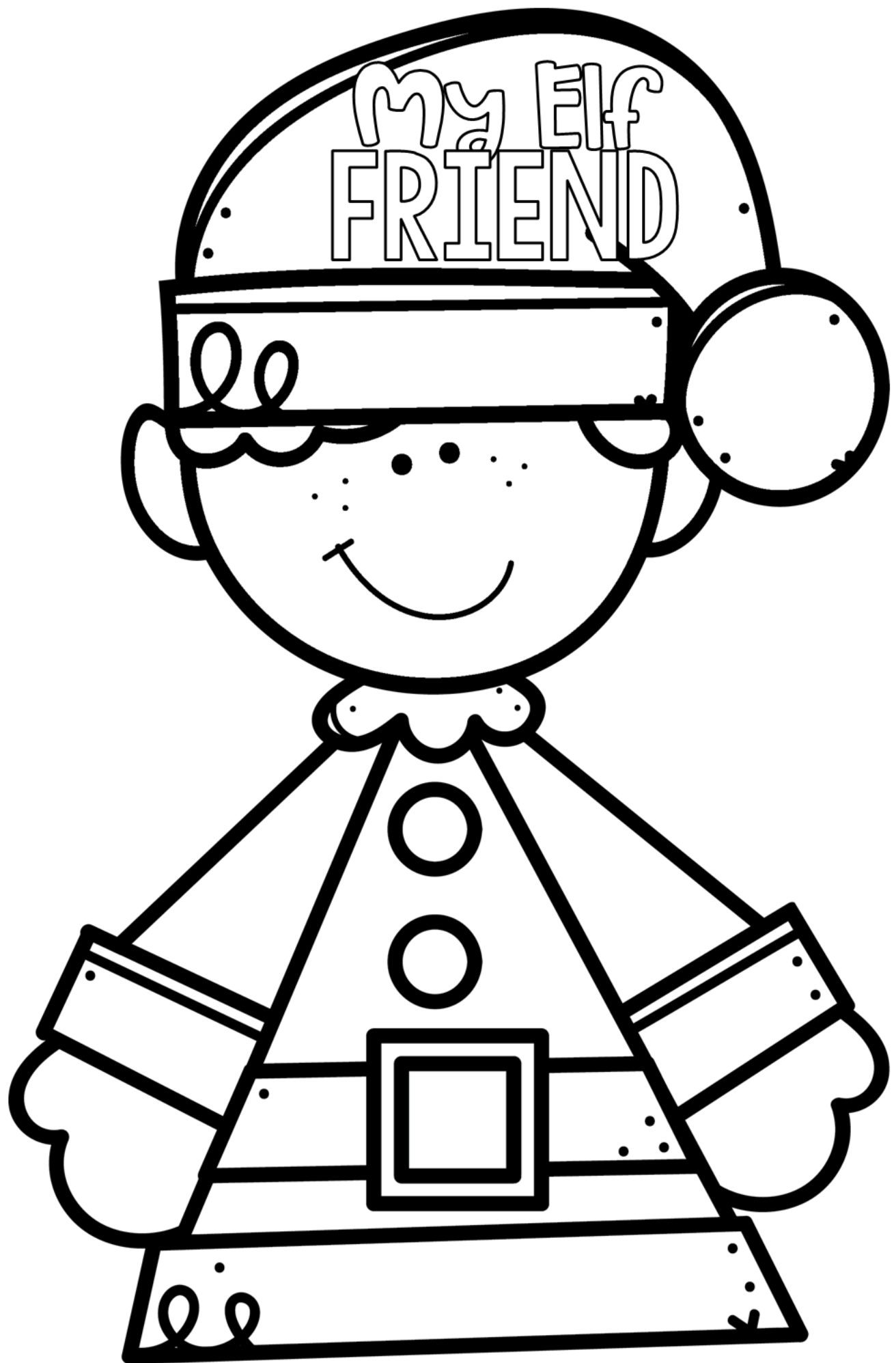

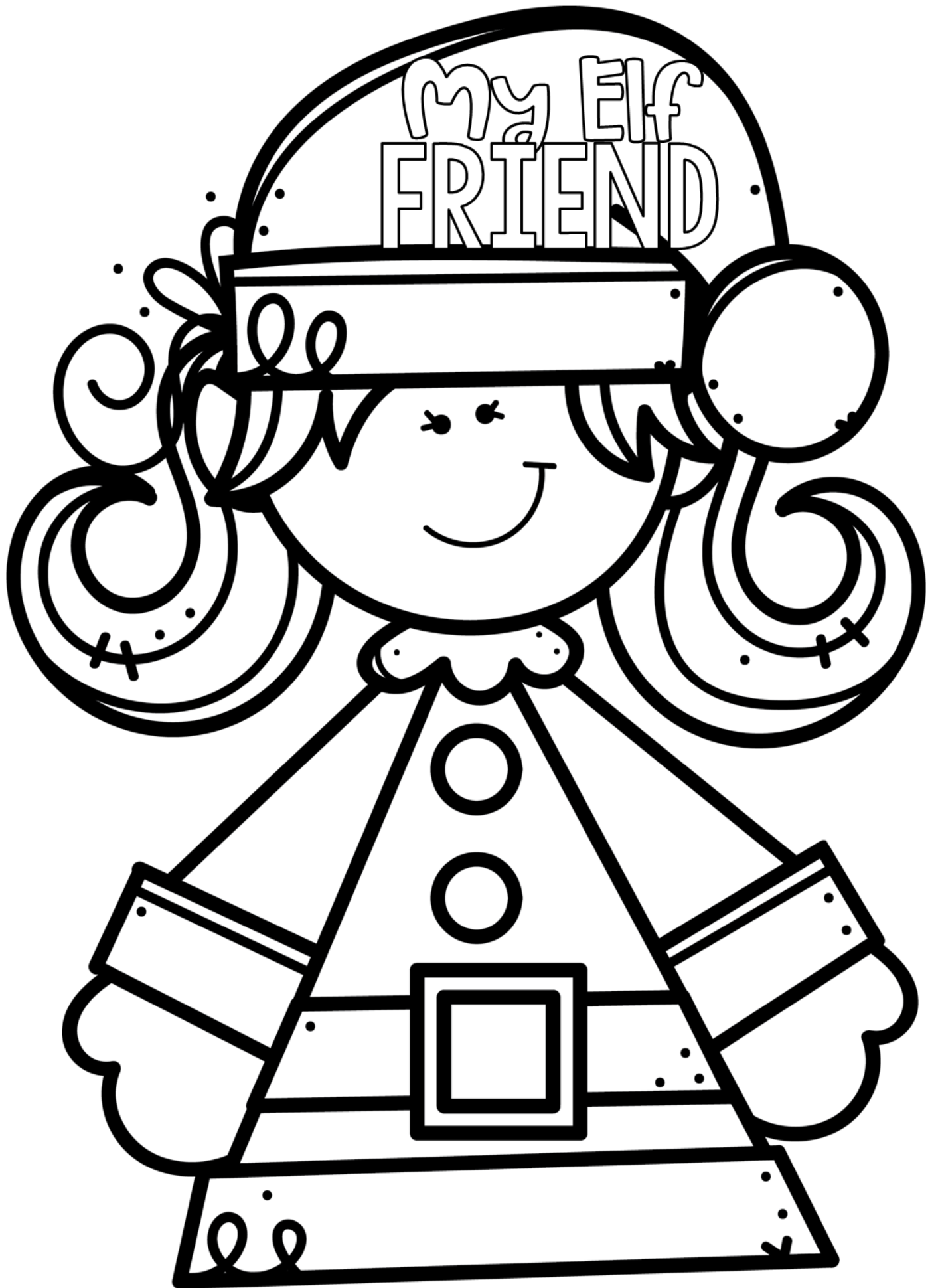

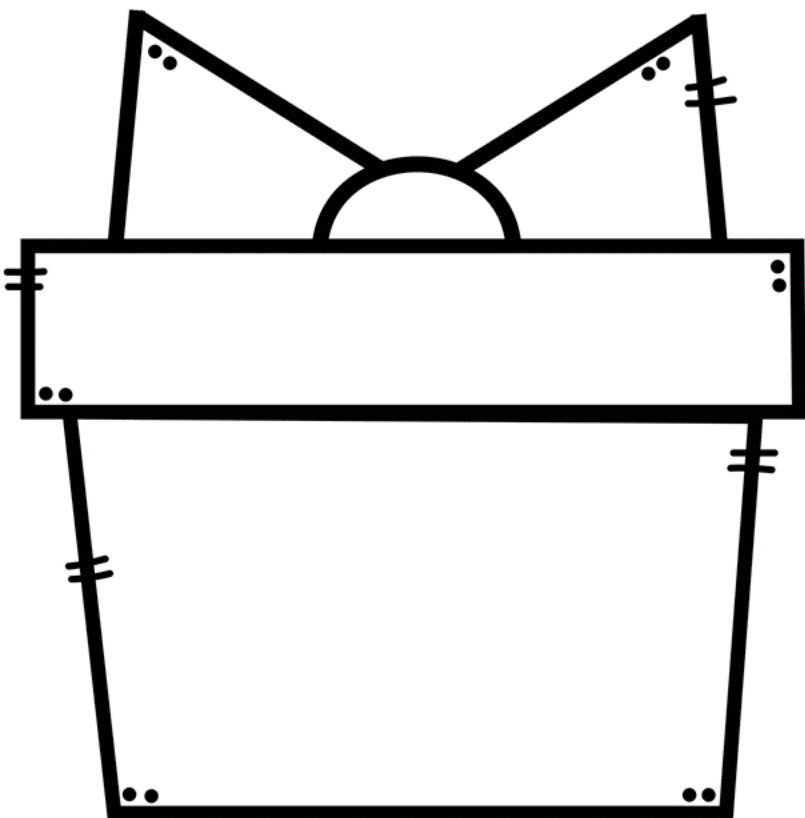
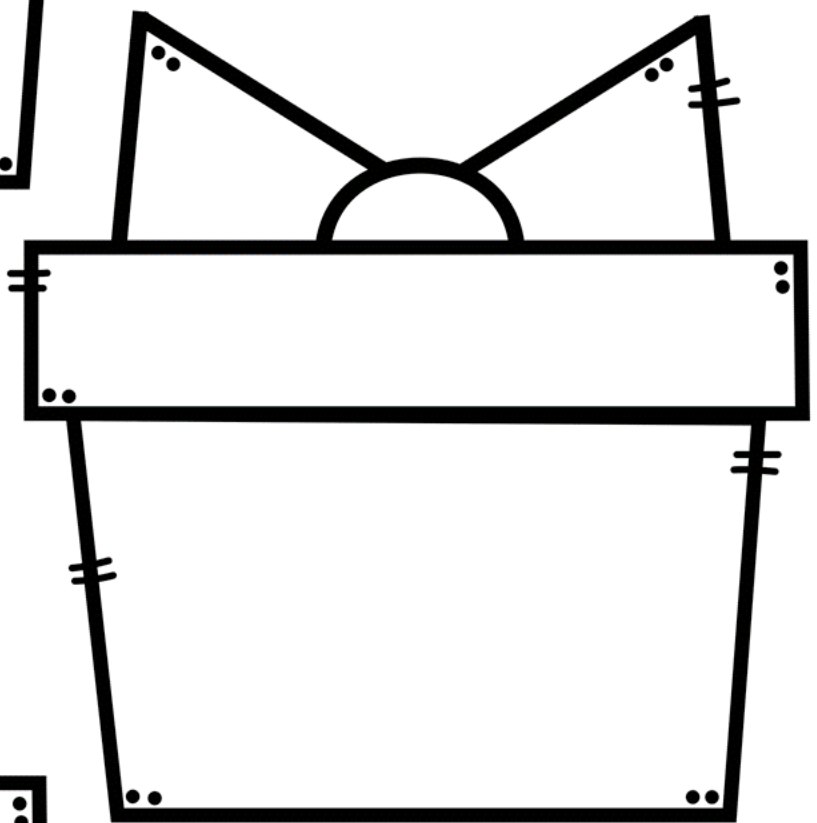
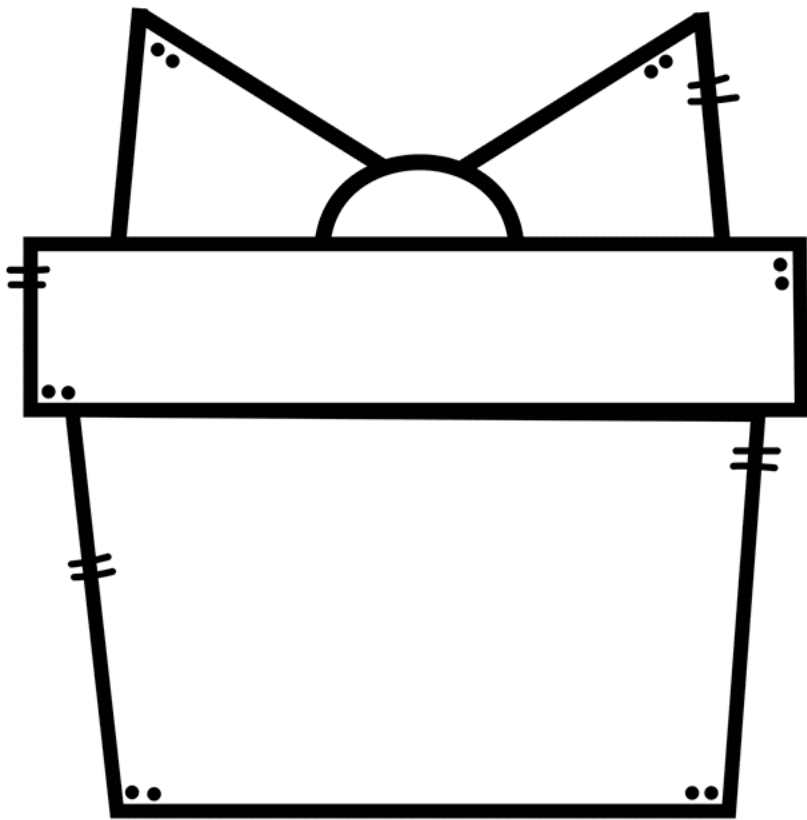

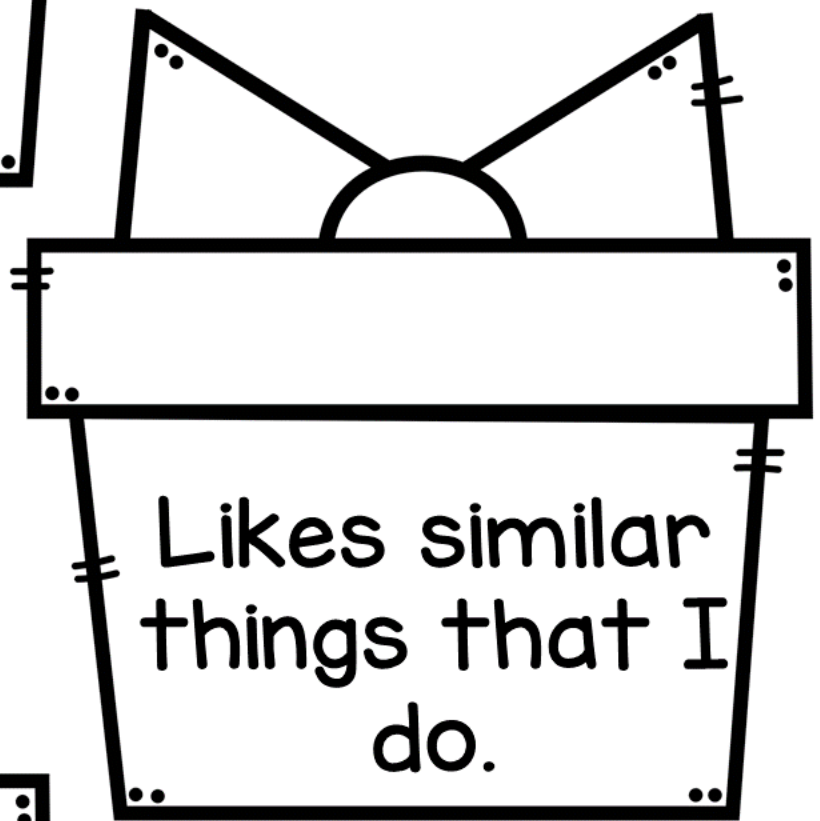
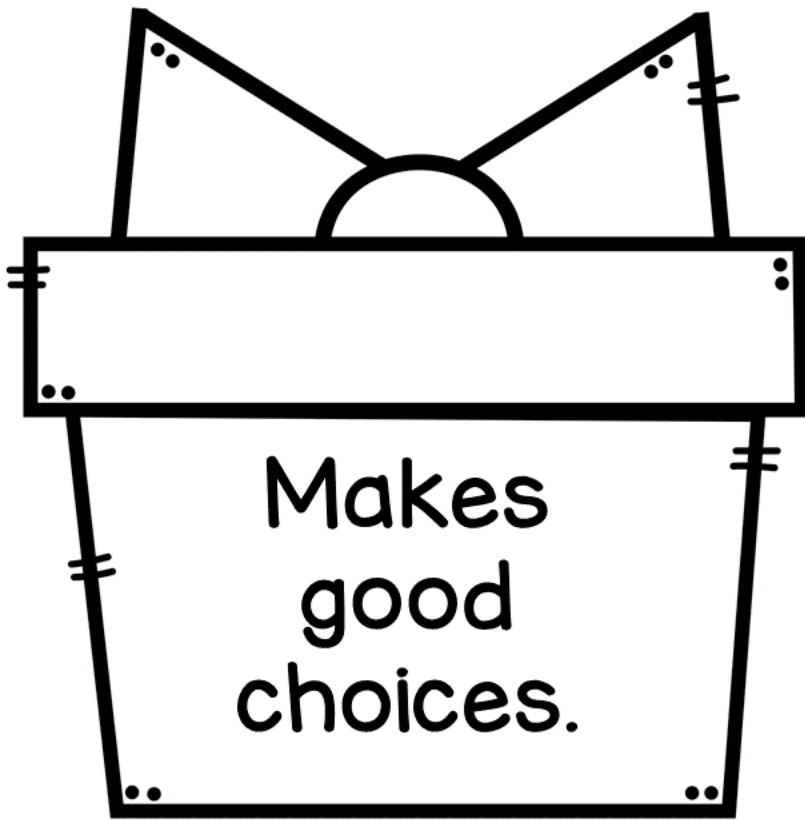

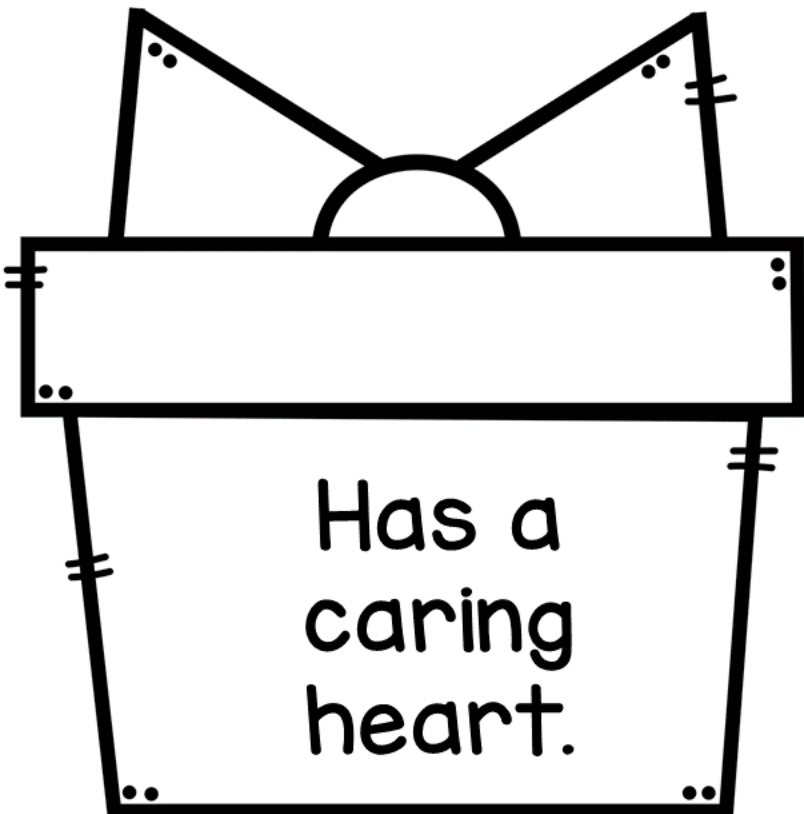
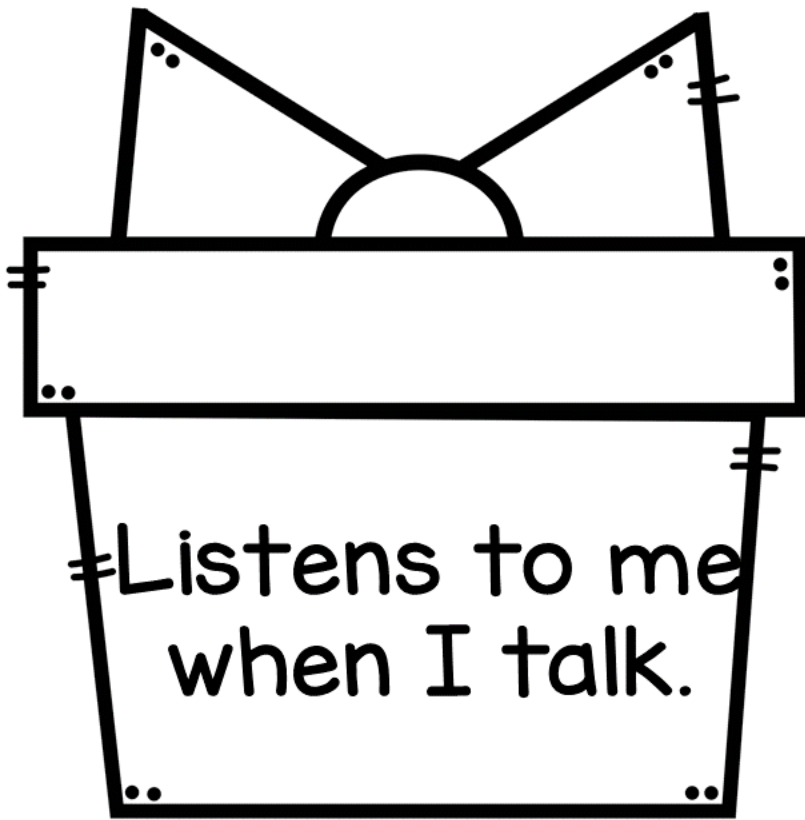

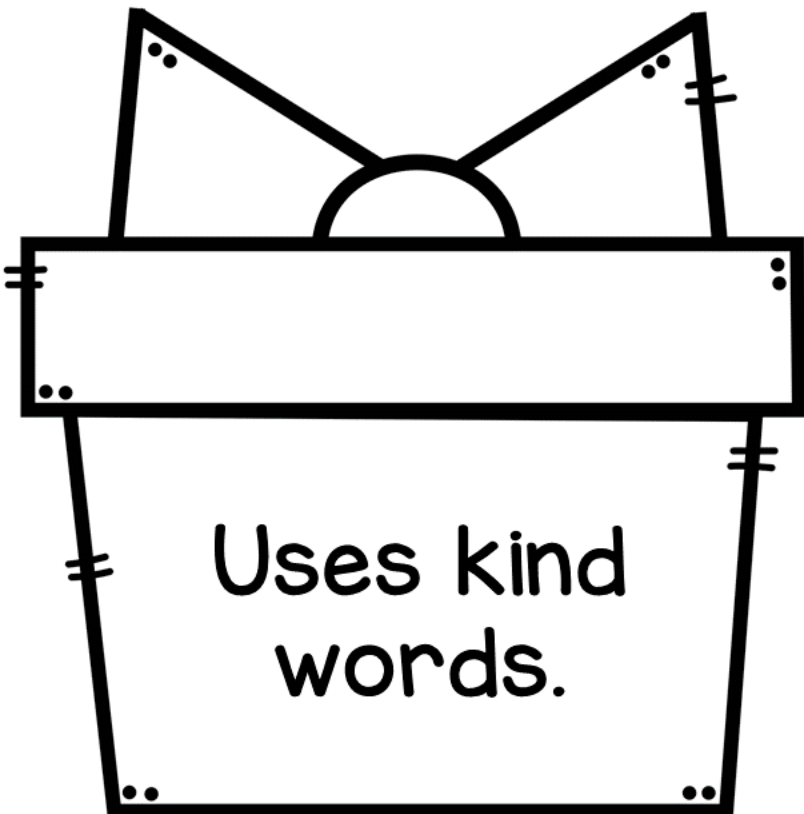
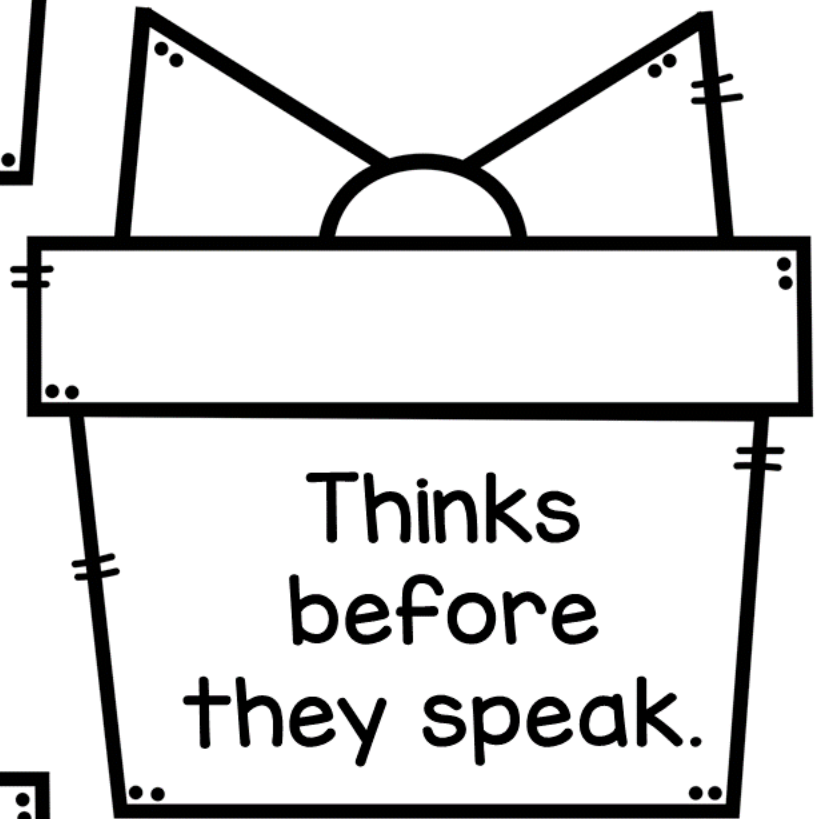

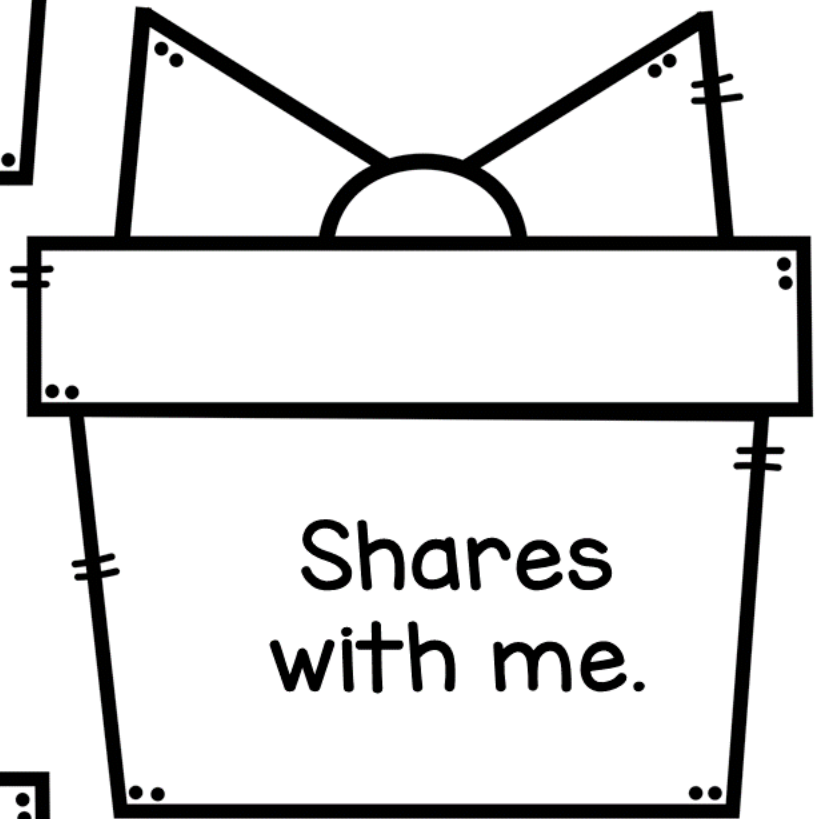
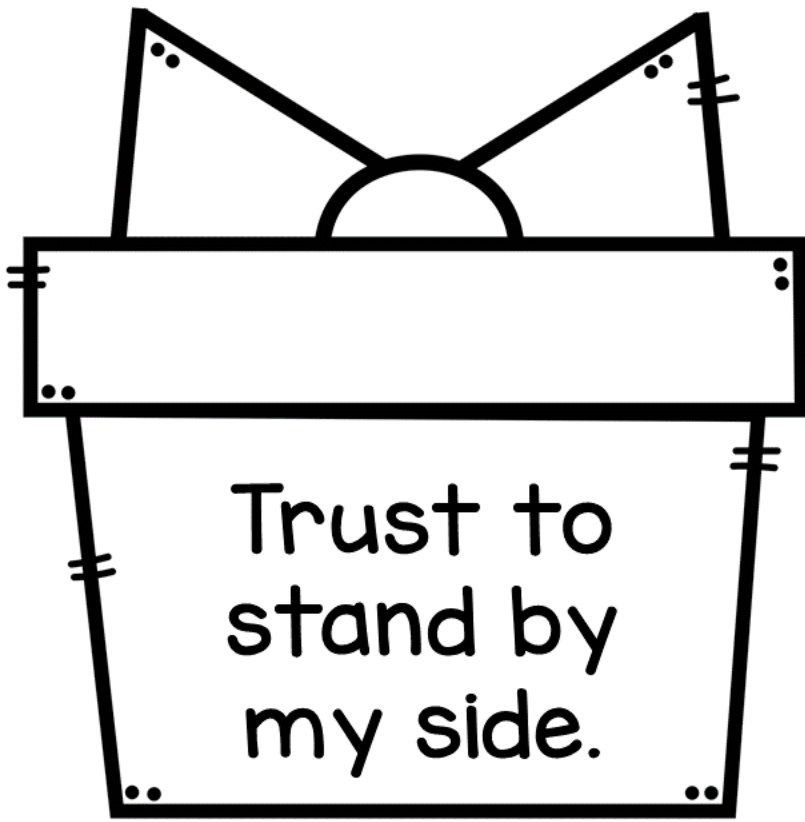

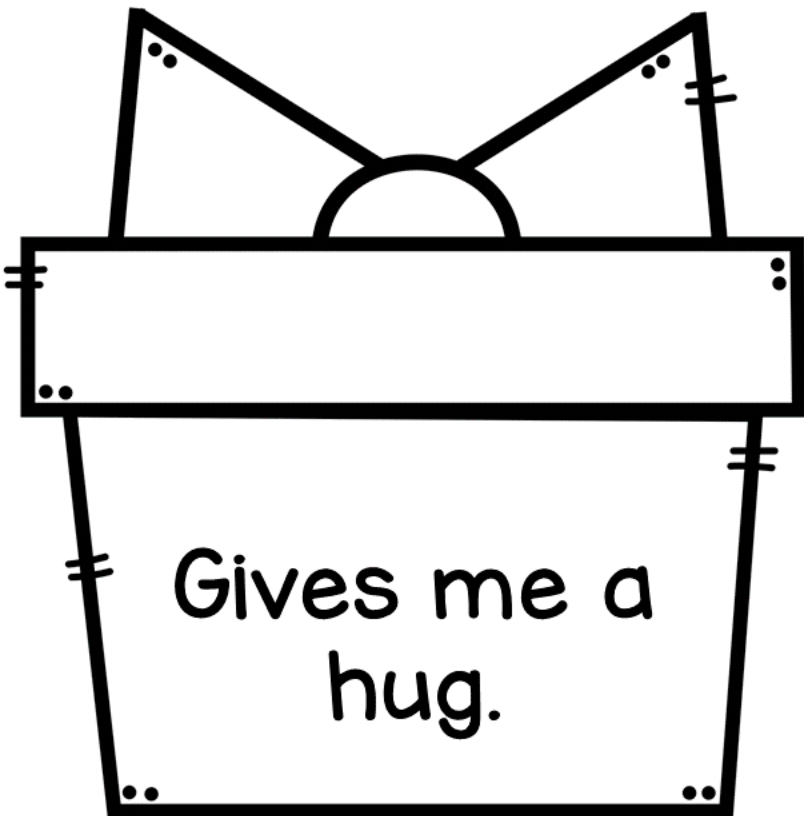
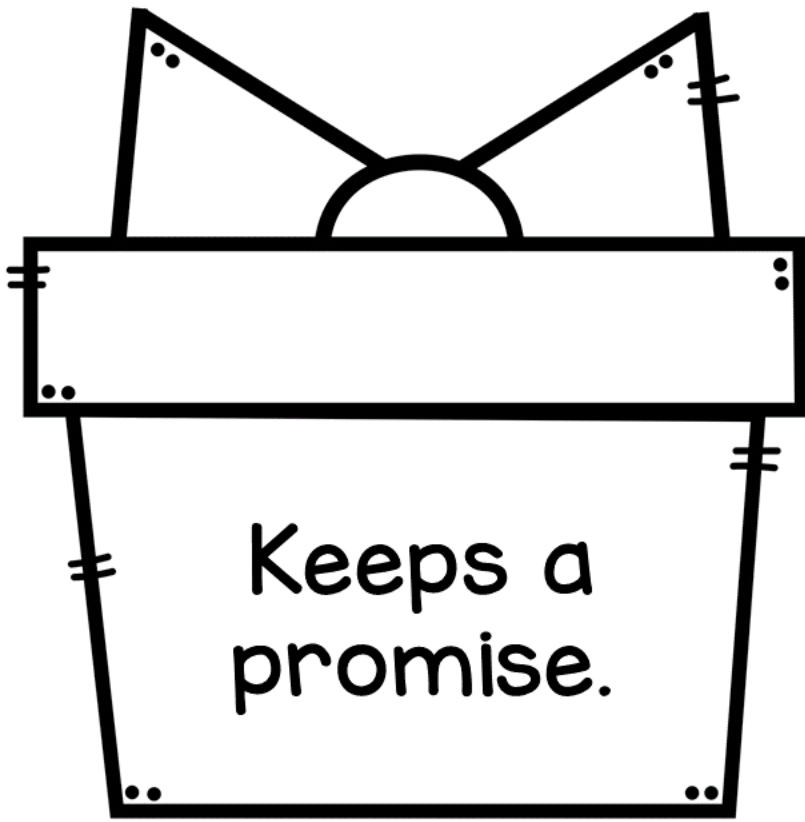

Why is it important for you to know what traits you value in a friend?



A large empty rectangular box for writing an answer to the question above.



Which quality is the most important one to you?

A large empty rectangular box for writing an answer to the question above.



Are the traits you put down on your "friend", traits that you have?

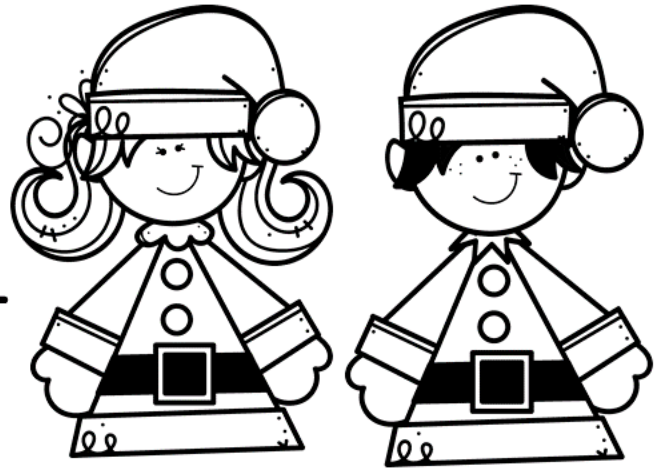

Blank space for writing answers to the first question.

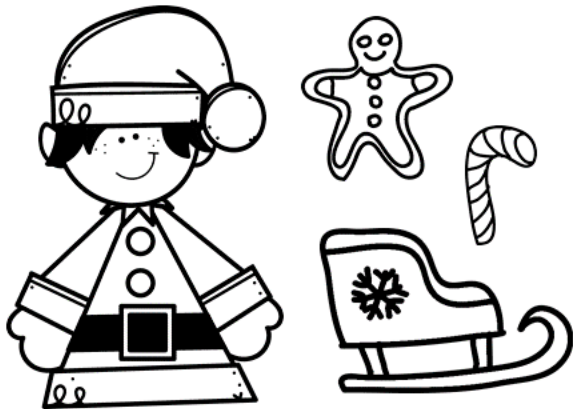

Are there any traits that you are working on and would like to get better at as a friend?

Blank space for writing answers to the second question.

GOOGLE CLASSROOM

Your resource comes with a digital version for use in Google Slides via Google Classroom. Follow these steps to upload your resource.

1 Click here → [Build an Elf Friend](#)

2 You will be prompted to make a copy of the resource. Click on the blue box that says "Make a copy" and the resource will go directly into your Google drive.

Google Drive

Copy document

Would you like to make a copy of Career Interest Inventory?

Make a copy



3 Go to your Google Drive and locate the copy of the file. You can rename the file at this point or add/delete slides.

4 Next, go to your Google Classroom and add an assignment. Select the Google Drive Symbol and select the resource you want to assign.

5 From here, you should see a grey box that says "Students can view file." Click the grey box. A dropdown menu should appear. Select, "Make a copy for each student."

YOU HAVE TO MAKE A COPY FOR EACH STUDENT!

Otherwise they will all be editing the same file.

Click "Assign" in the top right corner if you're ready to post!

This product is meant to be used in "edit" mode (not "presentation" mode). Edit mode is the only mode that allows drag & drop and writing in text boxes.

Helpful links for using Google Classroom:

[Teacher Tips for using Google Classroom \(TPT blog\)](#)

[Getting Started with Google Classroom \(youtube video\)](#)

ABOUT THE AUTHOR



Hi, I'm Ashley
SCHOOL COUNSELOR
Blogger & Creator

I have a B.A. in Psychology and an M.A. in School Counseling. I have a passion for creating fun and engaging resources for Counseling and Social Emotional Learning. I am a wife, and mother to 2 young boys.

Click the icons to connect with me Thank you for supporting my little shop.



Access my Freebie Library

RECOMMENDED RESOURCES

Click the pictures to get a closer look.

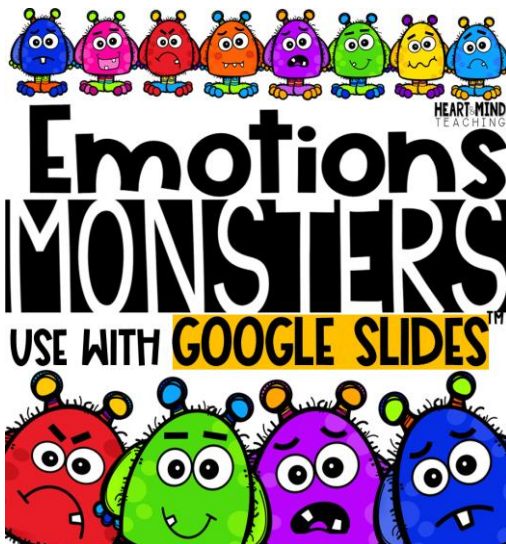

TERMS OF USE

© Heart and Mind Teaching, 2020. All rights reserved. Purchase of this item entitles the purchaser the right to reproduce for classroom, personal, and google classroom use only. Use in multiple classrooms, requires the purchase of additional licenses. Redistribution or duplication of this product is strictly forbidden without the written permission of the publisher. Copying any part of this product and placing it on a publicly accessible website is strictly forbidden and is a violation of the Digital Millennium Copyright Act (DMCA). You may post this for single-classroom use on a password protected student site such as google classroom. **You may NOT post my products on any public, for-profit, or commercial websites or entities such as Outschool.** Please do not sell or distribute any part of this as your own. Thank you for abiding by universally accepted codes of professional ethics while using this product.

Please feel free to contact me if you have any questions or feedback about this resource at:

heartandmindteaching@gmail.com



CREDITS



[Gayle McGlaulin](#)